



Roll Packers

PRODUCT GUIDE

ACM Roll Packers are the largest in their class and have the power and reliability to deal with the compaction of virtually all types of bulky waste, achieved using a specially constructed drum with steel teeth, crushing and shredding waste efficiently.

What do ACM Roll Packers offer?

Supplied with a 12-month warranty, our Roll Packers are immensely durable and offer a long operational life.

- Powerful crushing and compaction of waste can reduce the number of collections by over 80%.
- Reduction in number of trips to the recycling site means lower handling and haulage costs plus less CO2 emissions because fewer lorry journeys are made.
- Waste items that would be too large and bulky for a conventional compactor can be processed with an ACM Roll Packer.
- No preparation of waste for processing, such as cutting or folding, is necessary.
- The open container can be safely topped up with new waste during the compacting process until it is full.
- Swapping a full container for an empty one is a relatively quick and simple process.

WHO USES ROLL PACKERS?

Roll Packers are ideal for a range of large volume commercial waste producers, especially those that have bulky items requiring processing for disposal. These include:

- Manufacturers and warehouses
- Local authorities
- Storage and distribution companies (pallet waste)
- Building, renovation and demolition companies
- Printers
- Recycling and waste sorting plants
- Food distribution centres
- Woodworking industry and furniture companies
- Double glazing suppliers

WHAT WASTE MATERIALS CAN YOU PUT IN?

ACM Roll Packers offer excellent performance in dealing with a wide range of materials, including:

- Wood
- General waste
- Pallets
- Green waste
- Metals (including white goods)
- Certain specialised and various other materials

N.B Our Roll Packers are particularly suitable for handling wood waste, increasing tonnages in containers from approx. 1.5 tonnes usually to approx 8 tonnes.

FEATURES OF ACM ROLL PACKERS

Roll Packers provide a range of benefits to operators, including:

- Largest and heaviest in class, providing excellent compaction performance
- High compaction performance results in less journeys to waste disposal site
- Operation is simple and safe
- Low maintenance and 12 month warranty
- Continuous replenishment with new waste is possible during compaction process

To make full use of the space in the container, the spiked drum, which weighs 1.5 tonnes, breaks down the waste. A variety of drums are available to suit the type of waste to be compacted. The roll packer is able to deal with most types of bulky waste, from wood to washing machines, green waste to metalwork. The cycle time on the machines is variable allowing the machines to operate while you get on with other tasks.

ACM ENVIRONMENTAL SERVICE COMMITMENT?

With 25 years of waste management experience, we provide a nationwide collection service and a sustainable licensed recycling solution with full traceability for all types of commercial waste producer. ACM Environmental can provide a single port of call for all your waste management demands.

Roll Packers TECHNICAL SPECIFICATION

Technical Specifications	Product code	System pressure in the circuit	220 bar
Power (kW)	5.5	Hydraulic oil volume (l)	180
Electric motor revolutions (rev/min)	1500	Hydraulic oil	L-HV22
Input voltage/frequency	380-415 V / 50 Hz	Oil volume in the transmission (l)	6
Feeding by cable acc. to specifications	H07 RN-F	Oil in the transmission	VG 320
Plug	CEE 5 x 16A	Grease for central lubrication system	LT-43
Cycle Time (sec)	55	Dedicated to containers of length (mm)	5500x6000x6500
Fuses on user's side	3 x 25A	Maximum length of the container (mm)	6600
Control voltage (V)	24	Maximum width of the container (mm)	2650
Protection category	IP54	Maximum height of the container (mm)	3240
Hydraulic pumps	11 / 8 / 8 cm ³ / rev	Device weight (Kg)	3750

Notes: All machine dimensions are rounded up to the nearest 10mm. ACM reserve the right to alter the specification without prior notice.

Visit www.acmplc.com or call 08700 777 555

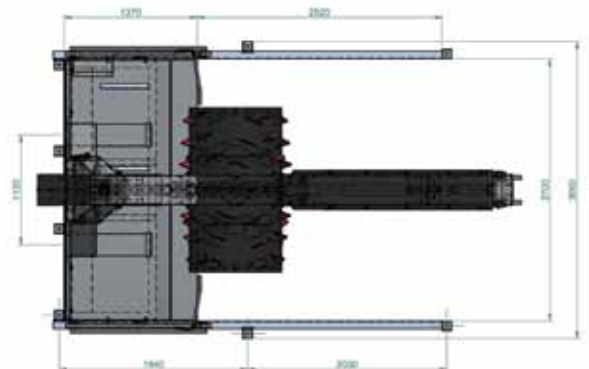
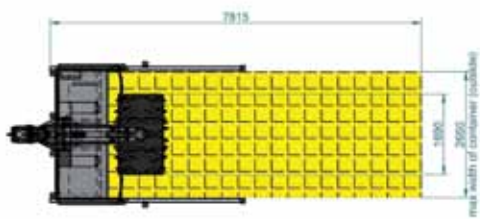
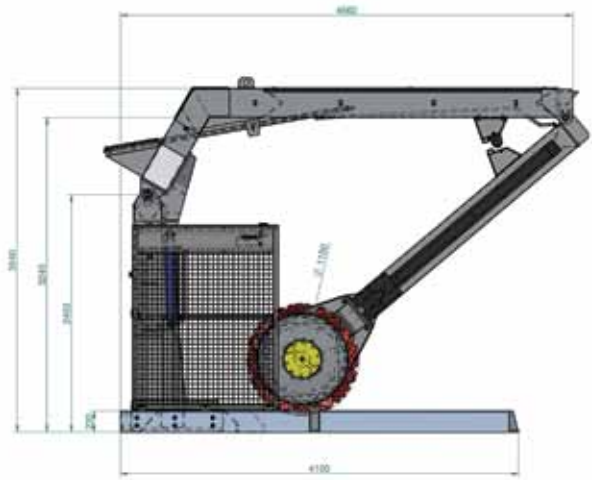
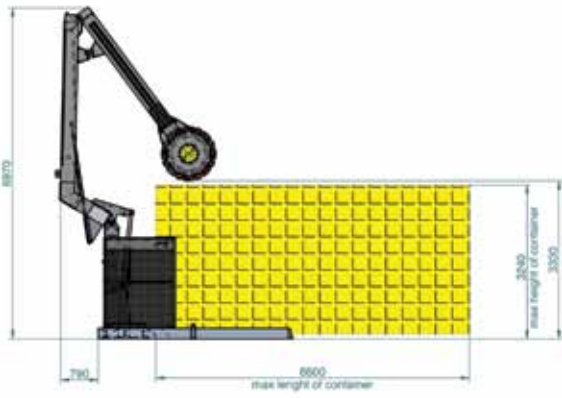

Other Core ACM Products

PORTABLE COMPACTORS

Designed to minimise use of space and to be used close to where waste is generated

STATIC COMPACTORS

Suitable for disposing of large quantities of waste economically

MID RANGE BALERS

Space saving and highly efficient recyclers for any material

MILL SIZE BALERS

Produces mill-sized bales for optimum financial return

CLOSED END HORIZONTAL BALERS

Air or conveyor fed semi-automatic baling of large quantities of recyclable materials



Call 08700 777 555

Visit www.acmplc.com

Email greenerpath@acmplc.com

ACM Environmental PLC, Eco House, Lea Road,
Waltham Abbey, Hertfordshire, EN9 1AS

Visit www.acmplc.com or call 08700 777 555